

Setup Guide



- FR Guide d'installation
- IT Guida all'installazione
- DE Installationsanleitung
- ES Guía de instalación
- PT Guia de Configuração
- NL Installatiehandleiding
- SV Installationsguide
- RU Руководство по установке

1 Unpack Printer

- FR Déballer l'imprimante
- IT Estrarre la stampante dalla confezione
- DE Drucker auspacken
- ES Desembale la impresora
- PT Retire a impressora da embalagem
- NL De printer uitpakken
- SV Packa upp skrivaren
- RU Распакуйте принтер

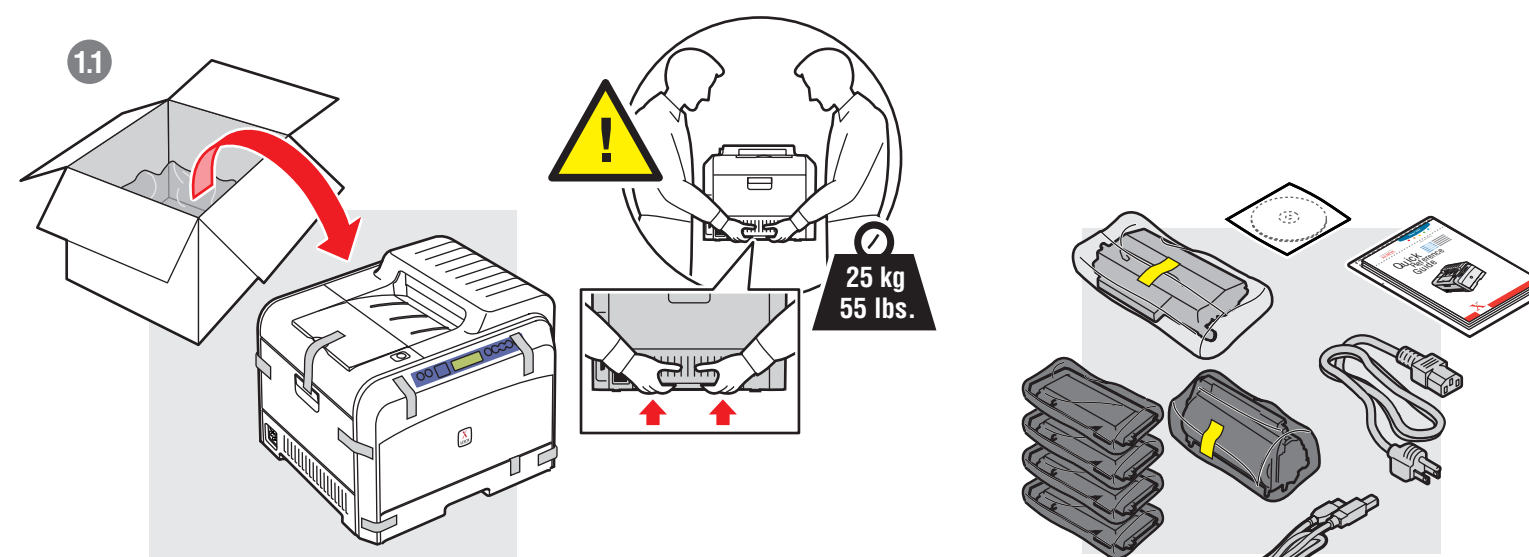

1.2 Remove Tape

- FR Retirez la bande adhésive
- IT Rimuovere il nastro
- DE Klebeband entfernen
- ES Extracción de la cinta
- PT Remova a fita
- NL Verwijder tape
- SV Ta bort tejp
- RU Удаление клейкой ленты

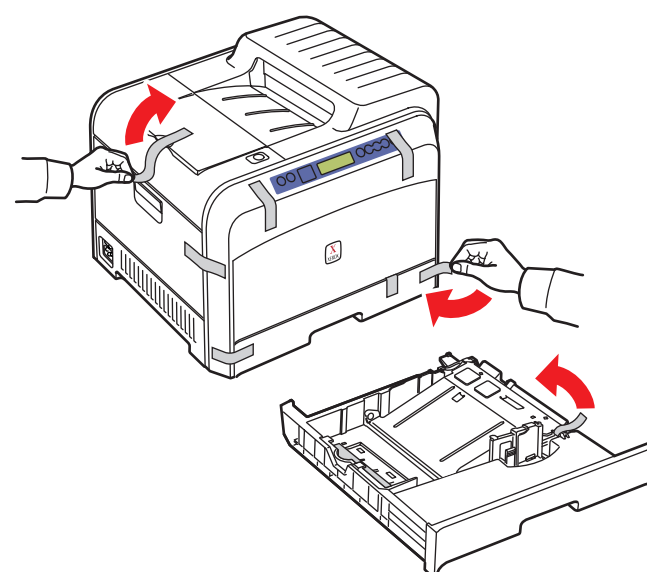

1.3

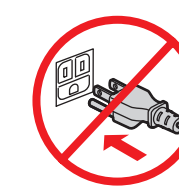
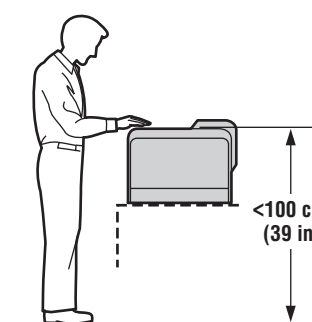
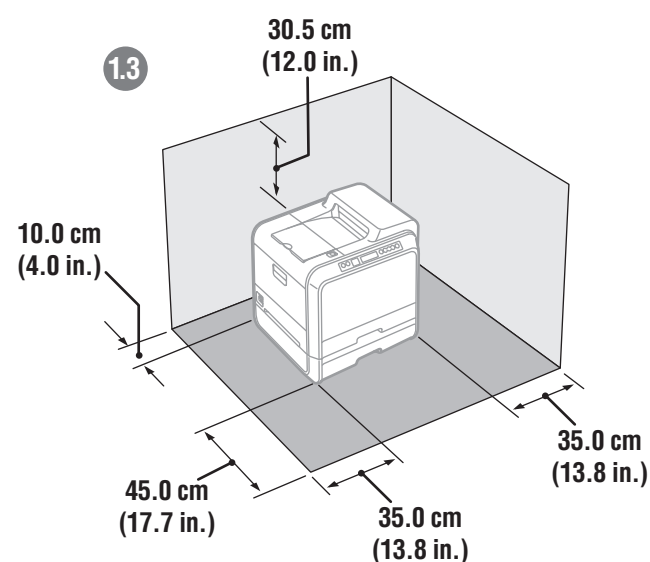

2 Install Imaging Unit

- FR Installez l'unité imageur
- IT Installare l'Unità Imaging
- DE Belichtungseinheit installieren
- ES Instale la unidad de imagen
- PT Instalar unidade de imagem
- NL Installeer de eenheid voor vastleggen beeld
- SV Installera bildenhet
- RU Установка копи-картриджа

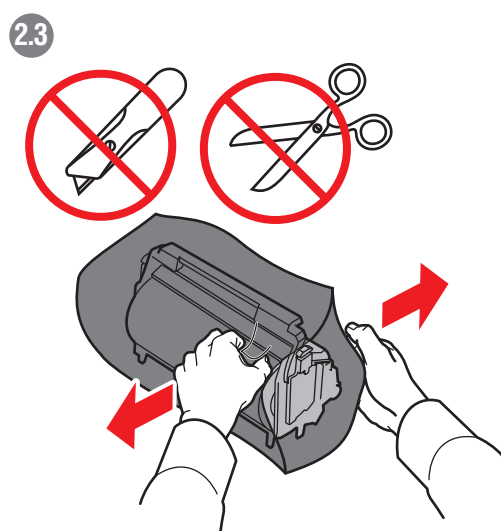
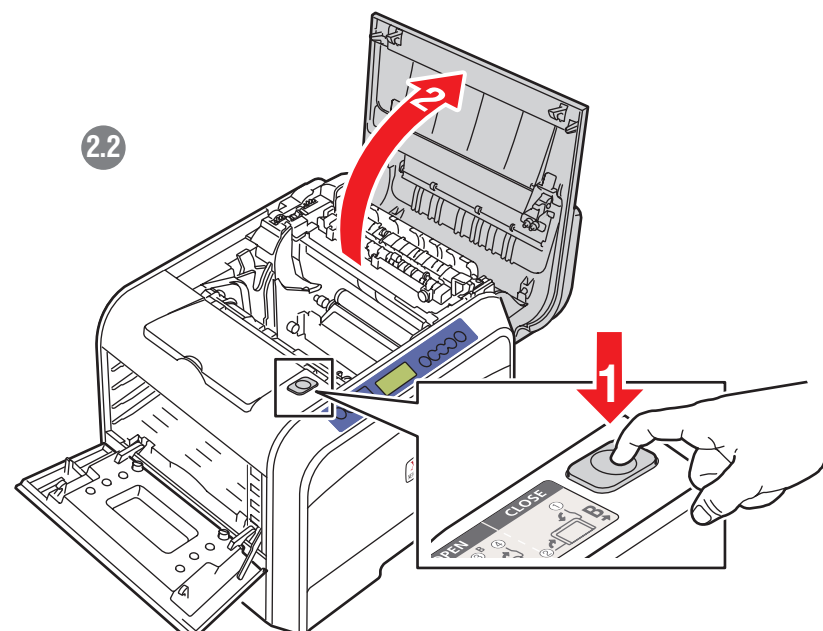
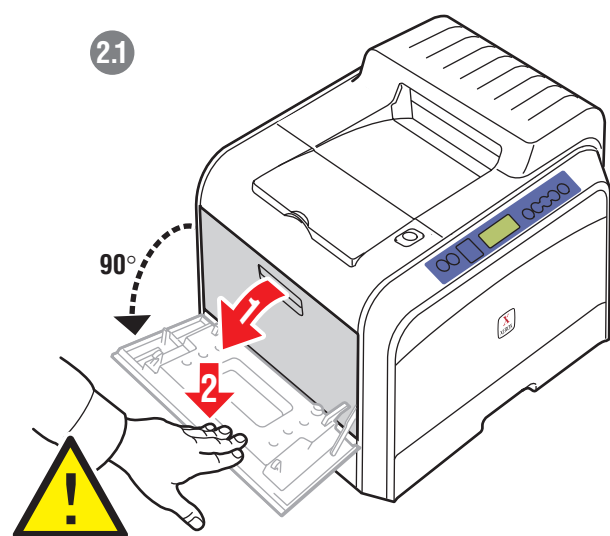
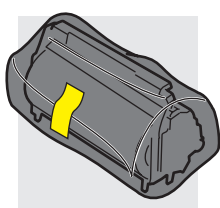

0:05:00
Limit Light Exposure

- FR Limiter l'exposition à la lumière
- IT Limite esposizione alla luce
- DE Nur kurz dem Licht aussetzen
- ES Limite de exposición a la luz
- PT Limite exposição à luz
- NL Beperk blootstelling aan licht
- SV Begränsa ljusexponering
- RU Не держите на свету

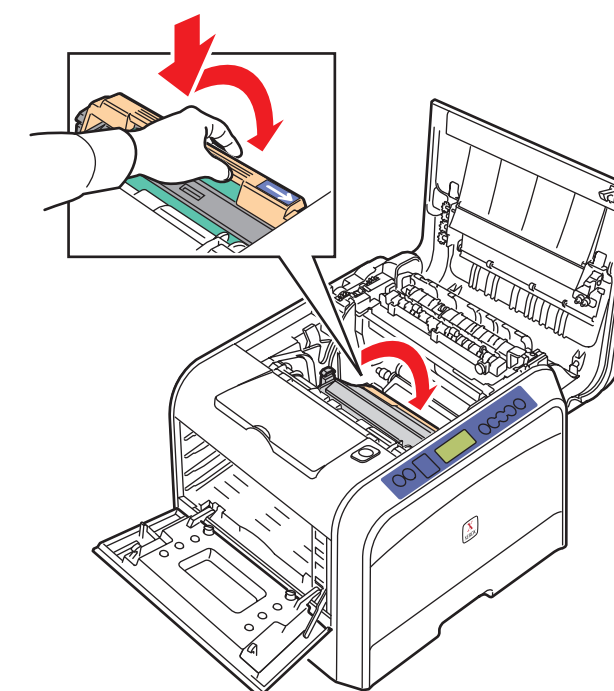
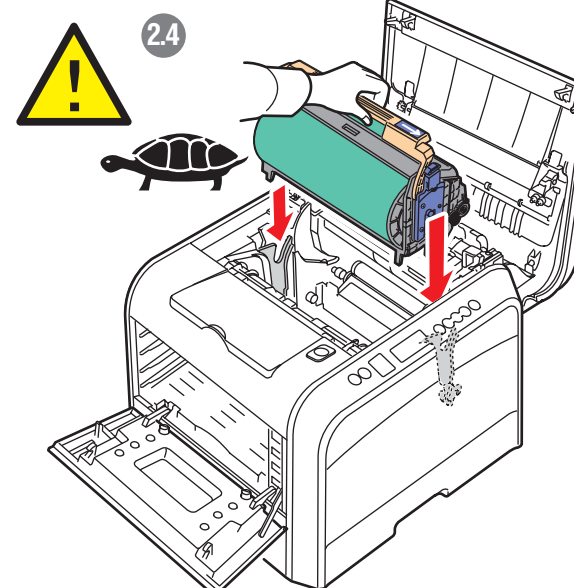
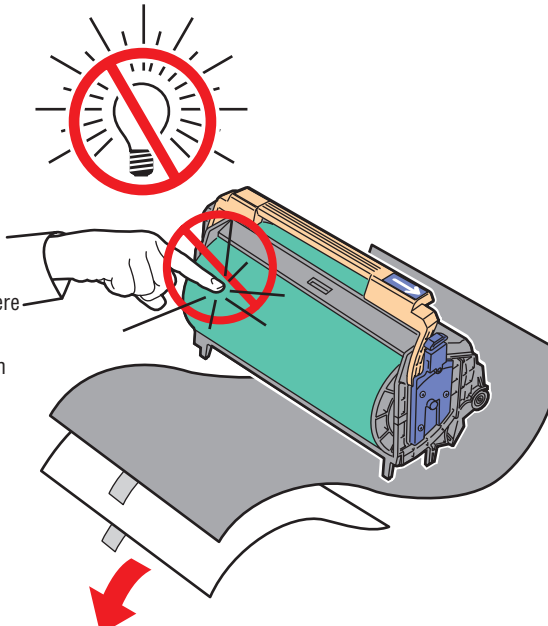

3 Install Transfer Belt

- FR Installez la ceinture de transfert
- IT Installare la cinghia di trasferimento
- DE Transferband installieren
- ES Instale la correa de transferencia
- PT Instale a correia de transferência
- NL Installeer de transferband
- SV Installera överföringsband
- RU Установите ремень переноса

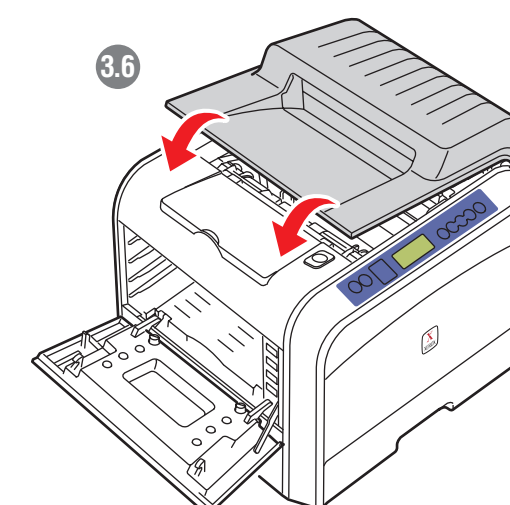
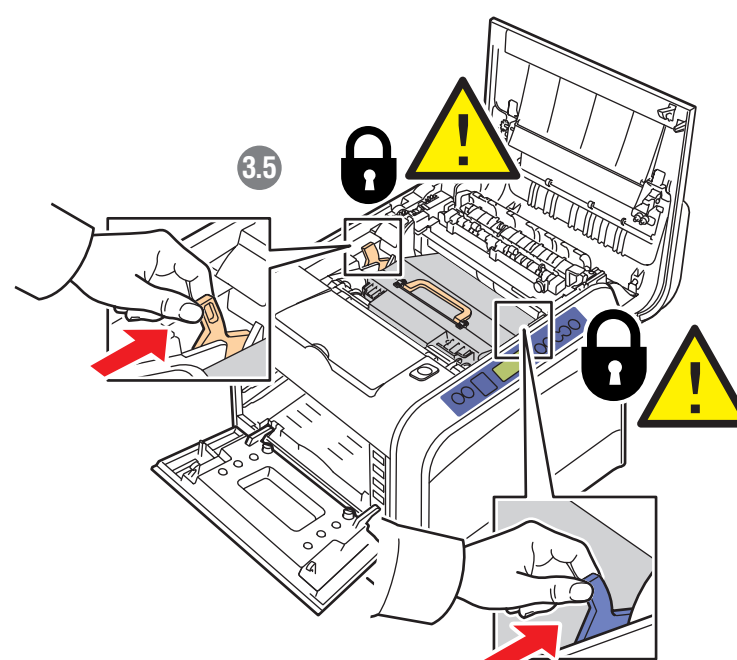
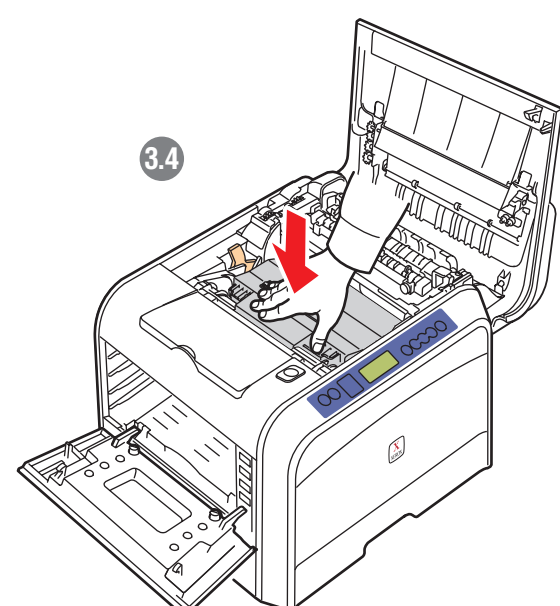
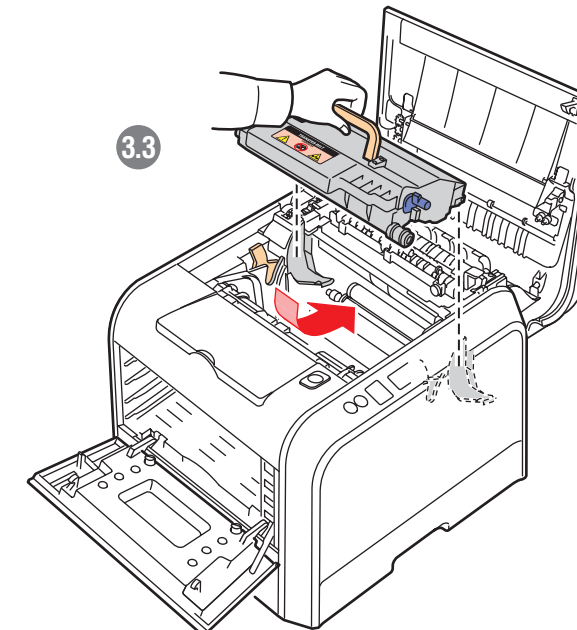
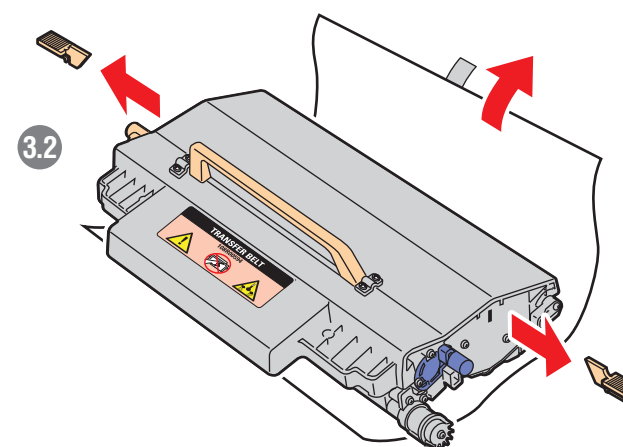
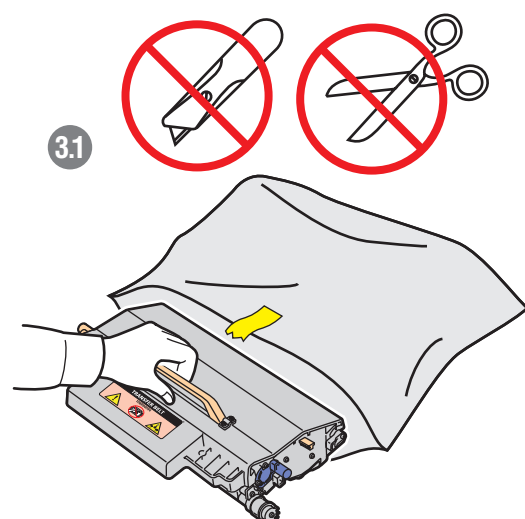
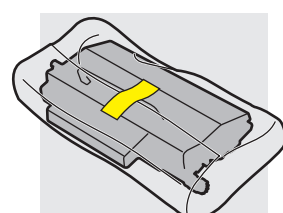

4 →

4 Install Toner Cartridges

- FR Installez les cartouches de toner
- IT Installare le cartucce di toner
- DE Tonerkartuschen installieren
- ES Instale los cartuchos de tóner
- PT Instale os cartuchos de toner
- NL Installeer de tonercassettes
- SV Installera tonerkassetter
- RU Установка картриджей с тоном

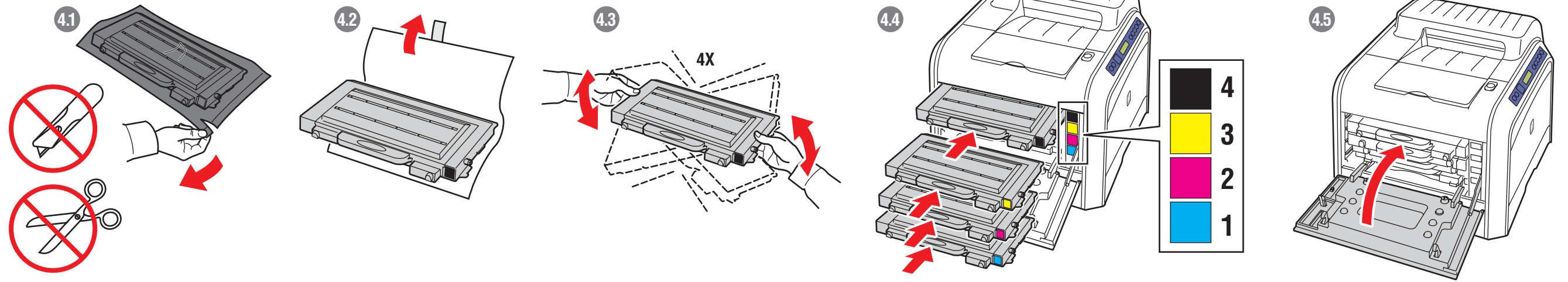
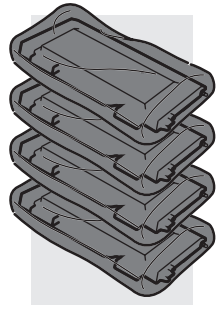

5 Load Paper Tray

- FR Chargez le bac d'alimentation
- IT Caricare il cassetto della carta
- DE Papier einlegen
- ES Carga de la bandeja de papel
- PT Coloque papel na bandeja
- NL Plaats papier in lade
- SV Fyll på papperfack
- RU Загрузка лотка для

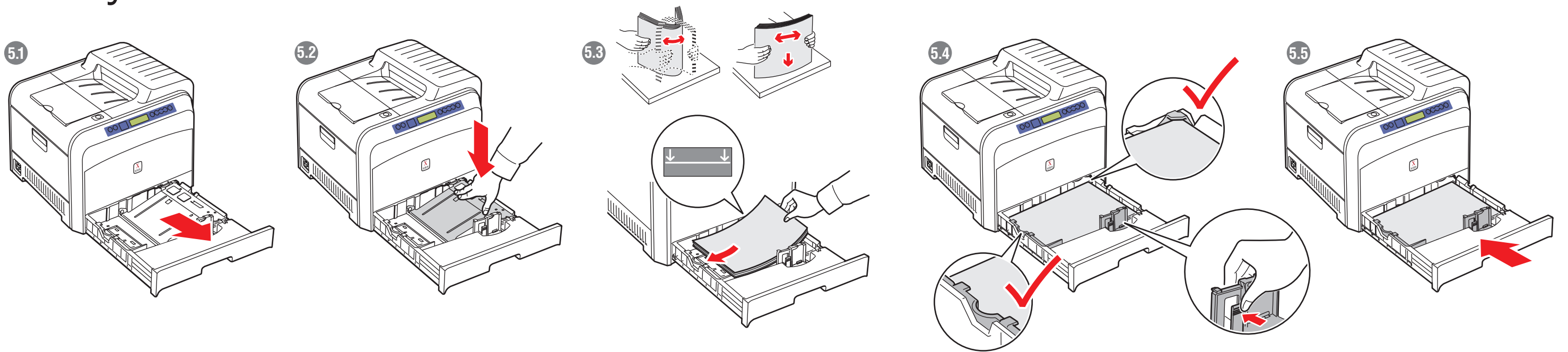

6 Choose Printer Connection

- FR Choisissez une connexion d'imprimante
- IT Scegliere la connessione della stampante
- DE Druckeranschluss wählen
- ES Elija la conexión de la impresora
- PT Escolha a conexão com a impressora
- NL Kies de printerverbinding
- SV Välj skrivaranslutning
- RU Выбор подключения принтера

Ethernet
TP

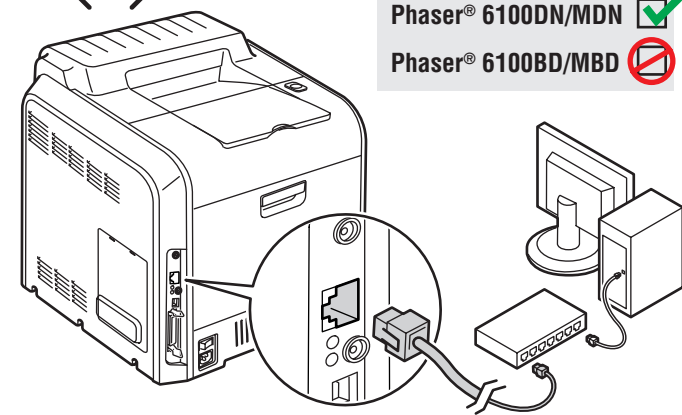

Use Ethernet hub and RJ-45 cables.

- FR Utilisez un concentrateur Ethernet et des câbles RJ-45.
- IT Utilizzare un hub Ethernet e cavi RJ-45.
- DE Ethernet-Hub und RJ-45-Kabel verwenden.
- ES Utilice un concentrador Ethernet y cables RJ-45.
- PT Use o hub Ethernet e os cabos RJ-45.
- NL Gebruik een Ethernet-hub en RJ-45-kabels.
- SV Använd Ethernet-hubb och RJ-45-sladdar.
- RU Используйте концентратор Ethernet и кабели RJ-45.

USB

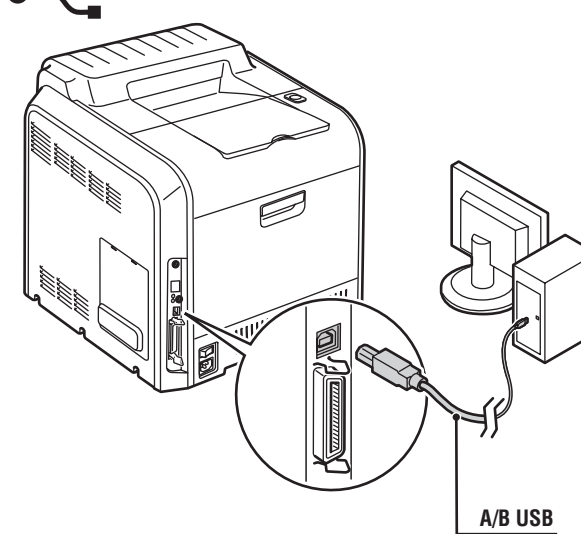

Parallel
//

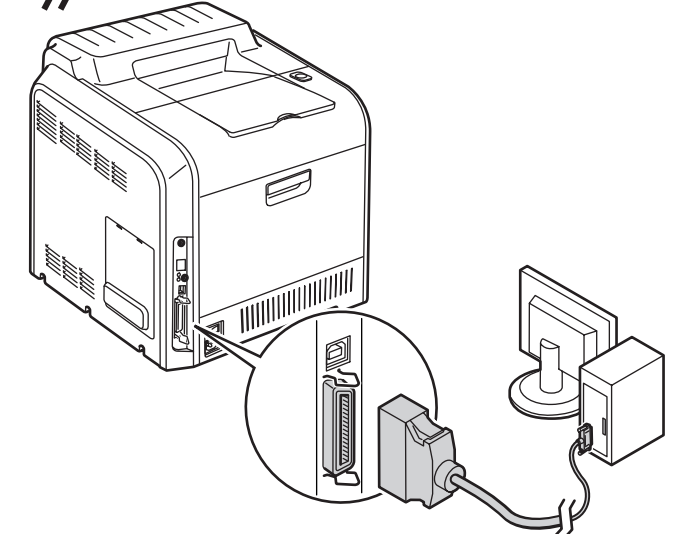

7 Turn On Printer

- FR Mettez l'imprimante sous tension
- IT Accendere la stampante
- DE Drucker einschalten
- ES Encendido de la impresora
- PT Ligue a impressora
- NL Zet de printer aan
- SV Sätt på skrivaren
- RU Включение принтера

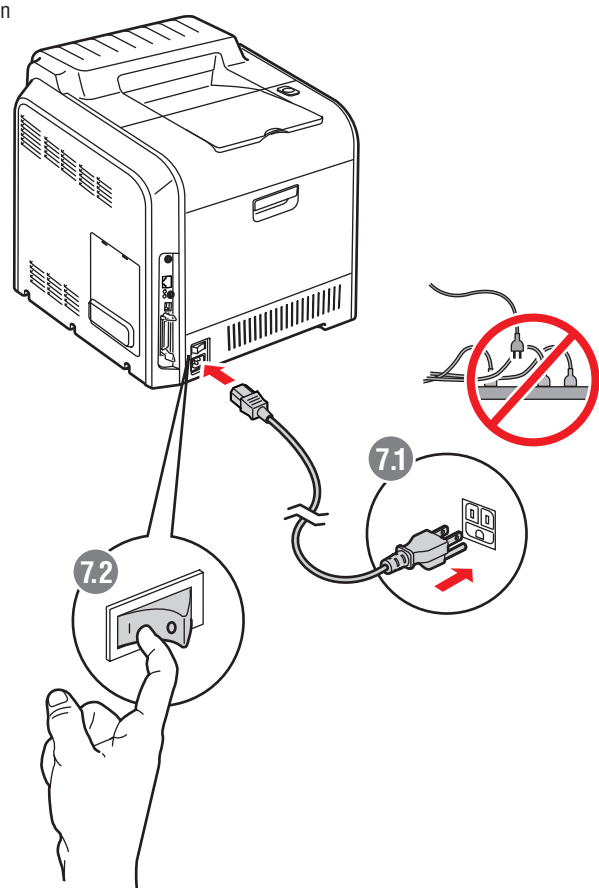

8 Select Language

- FR Sélectionnez la langue
- IT Selezionare la lingua
- DE Sprache auswählen
- ES Seleccione el idioma
- PT Seleccione o idioma
- NL Selecteer een taal
- SV Välj språk
- RU Выбор языка

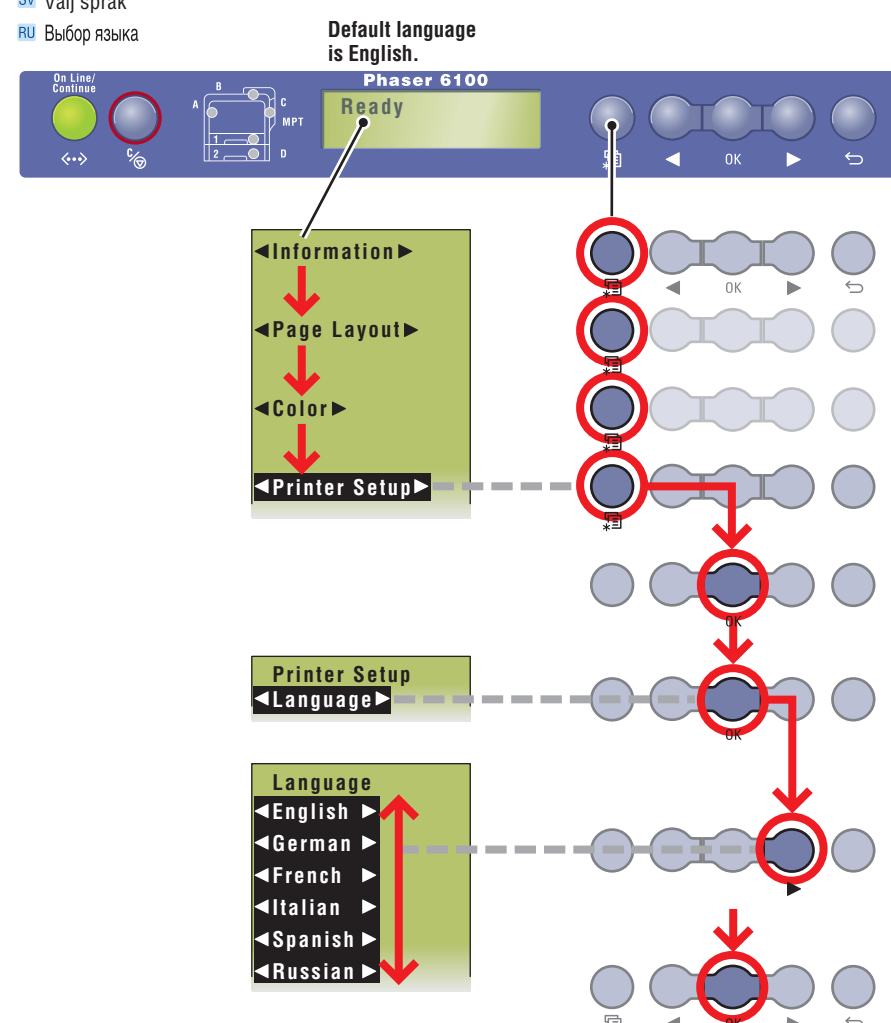

9 Install Drivers

- FR Installez les pilotes
- IT Installare i driver
- DE Treiber installieren
- ES Instalación de controladores
- PT Instale os drivers
- NL Stuurprogramma's installeren
- SV Installera drivrutiner
- RU Установка драйверов

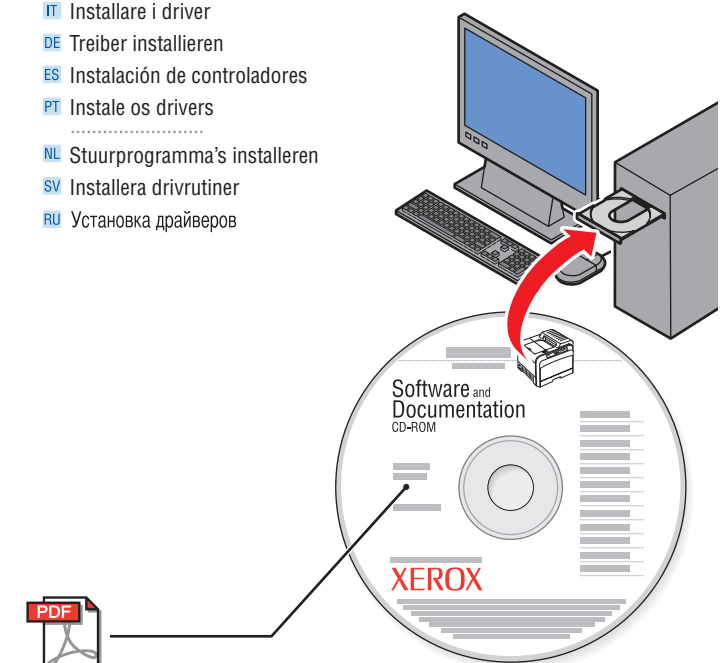

For networking information

- FR Pour des informations de mise en réseau
- IT Per informazioni sulla rete
- DE Netzwerkinformationen
- ES Para obtener información de red
- PT Para obter informações sobre a rede
- NL Voor netwerk informatie
- SV För nätverksinformation
- RU Сведения о сетевом подключении

