

## *Upgrading a Phaser® 200e, 200i or 220e printer to a Phaser® 240*

This kit contains the components necessary to upgrade a Phaser 200e, 200i or 220e to a Phaser 240 Color Printer. Generally, this involves replacing the printer's old image processor board with a new image processor board. In the case of the Phaser 200e and 200i, the printer's engine control board must also be replaced with a new engine control board included in this kit. In all cases, the unused or replaced components must be returned to Tektronix. This upgrade should only be installed by qualified service personnel.

### **Kit contents**

- Phaser 240 image processor board
- print engine controller board
- 8-Mbyte RAM SIMM
- Ethernet card (Option P1)

### **Static electricity precautions**

- Plug in the ground adapter (003-1501-00) in an AC outlet. Connect the anti-static mat (006-7056-00) to the adapter's groundplug.
- Put on your anti-static wrist strap and connect it to the anti-static mat.
- Leave the printer plugged into its power outlet; this preserves a ground path for static discharges.
- Touch the printer's bare metal frame often to discharge static electricity from your body.
- Handle the circuit board(s) by their edges only.
- Do not lay the board(s) on a metal surface.
- Avoid wearing nylon or polyester clothing; they generate static electricity.

## Removing the old boards

### Tools required

- #1 POSIDRIV® screwdriver

1. Power down the printer. Leave the power cord plugged in to provide a ground path for static discharges. Remove the interface cables.
2. Remove the top-rear and rear cabinet panels.
3. Remove the screws securing the old I/O board to the card cage.
4. Disconnect the I/O board's ribbon cable(s) from the image processor board. The Phaser 220i and 200i I/O boards have two ribbon cables; the Phaser 220e and 200e I/O boards have one ribbon cable. Remove the I/O board.

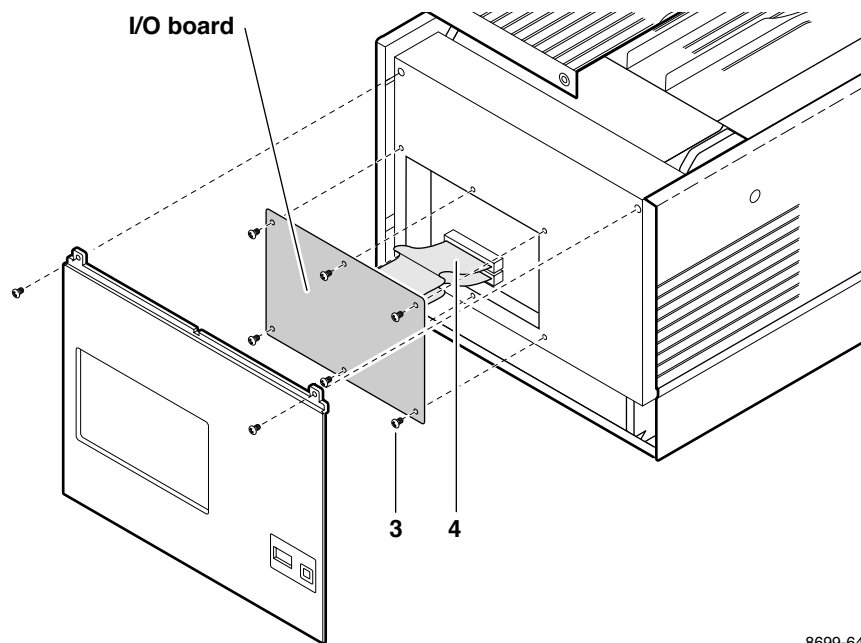

8699-64

5. Remove the card cage top (3 screws).
6. Flip over the hinged card cage top.
7. Lift out the old image processor board.

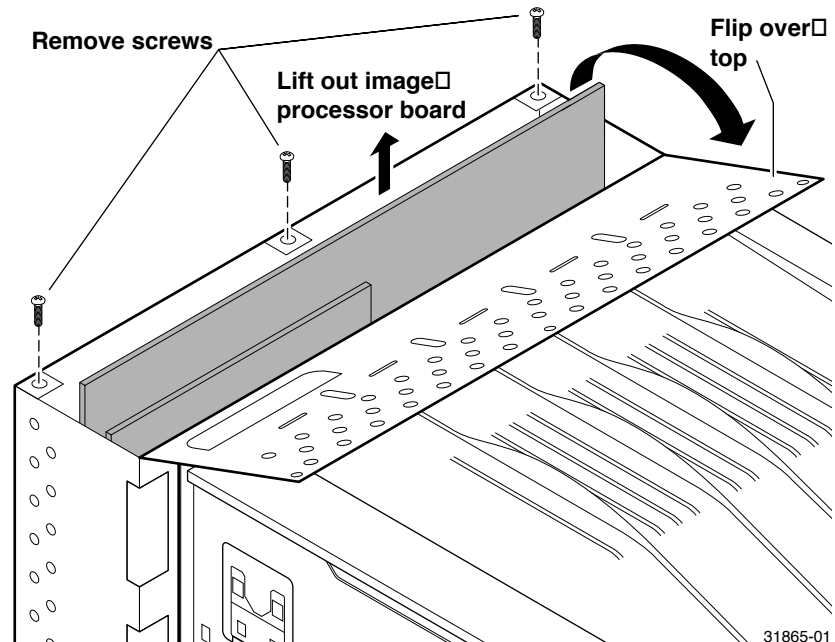

**Note** *In the next step, it is only necessary to remove the old engine control board from a Phaser 200e or Phaser 200i Color Printer.*

8. Disconnect the wiring harnesses leading to the engine control board.

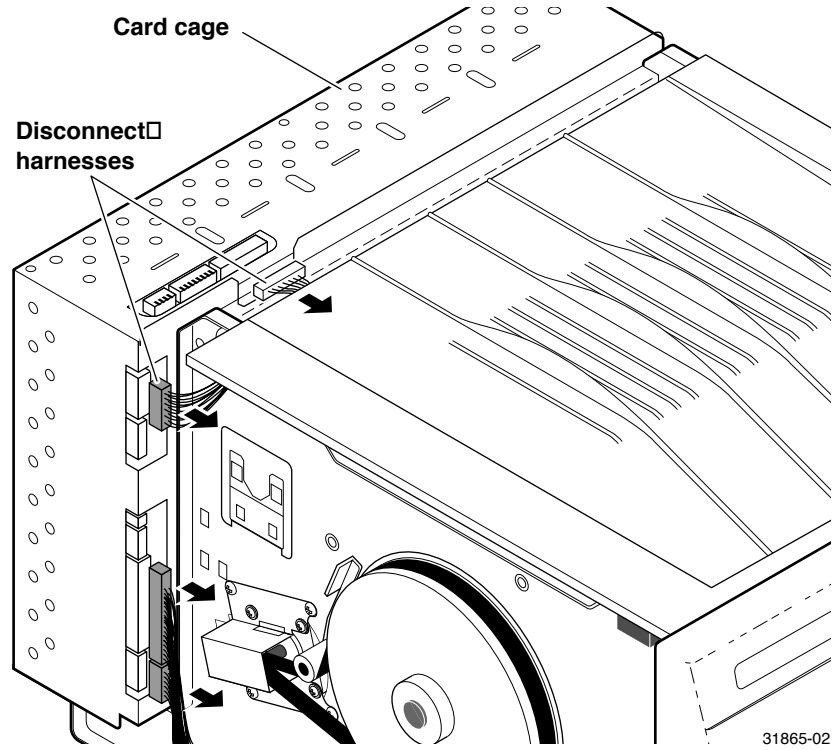

9. Lift out the engine control board.

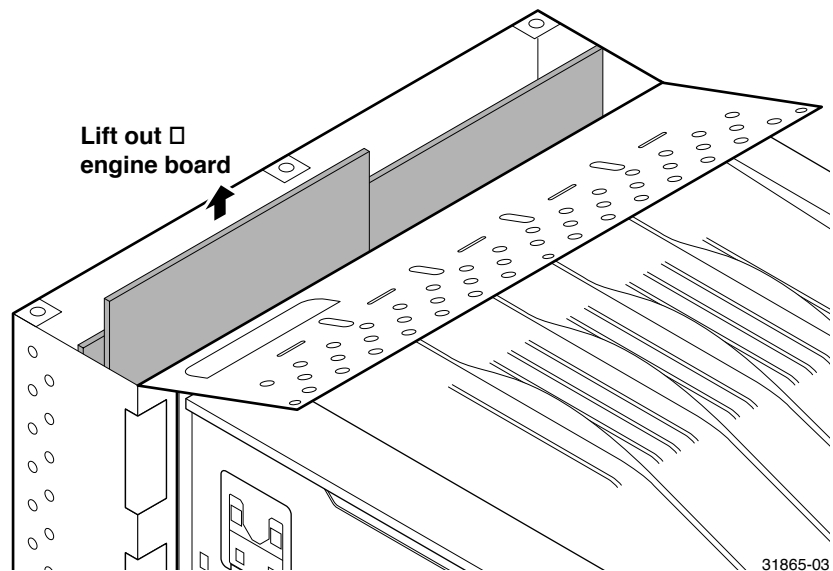

## SIMM installation on the new image processor board

1. If installed, remove the font module by spreading the pawls at each end of the font module connector securing the module in place.
2. **Installing the RAM SIMM.** Insert the RAM SIMM in connector J7 (a), and tilt the card upright until it locks in place (b). When properly inserted, a tab on each end of the connector slips into a hole on each end of the card. Also, a pawl on each end of the connector latches around each end of the card to lock it in place.
3. **Installing the Ethernet card.** Insert the Ethernet card in connector J30 (a), and tilt the card upright until it locks in place (b). When properly inserted, a tab on each end of the connector slips into a hole on each end of the card. Also, a metal pawl on each end of the connector latches around each end of the card to lock it in place.

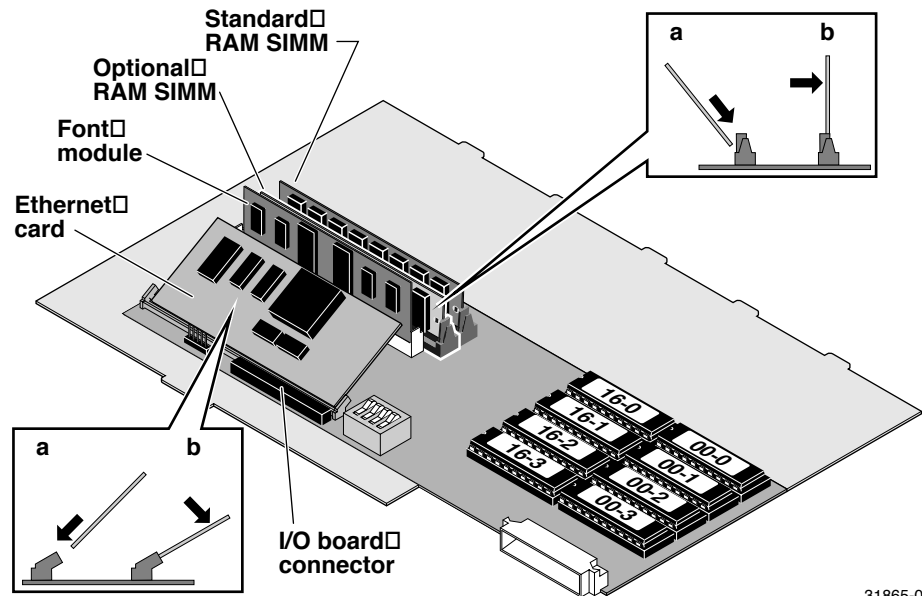

31865-04

4. Reinstall the font module, if removed. Like the RAM SIMM, when properly inserted, a tab on each end of the connector slips into a hole on each end of the card. Also, a pawl on each end of the connector latches around each end of the card to lock it in place.

## New image processor install

1. Slide the new image processor board into its card cage slot.

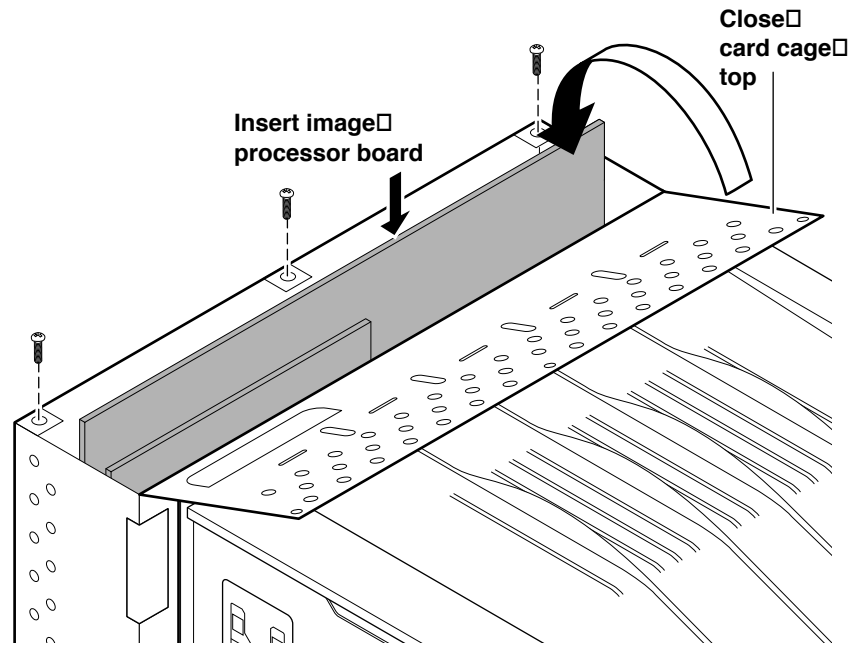

2. Close the card cage cover and secure it in place.
3. Reinstall the printer covers.

4. Connect the I/O board's ribbon cable to the image processor board's I/O connector. Tilt the I/O board forward into place against the rear of the printer's card cage. Secure the I/O board in place with the two thumbscrews.

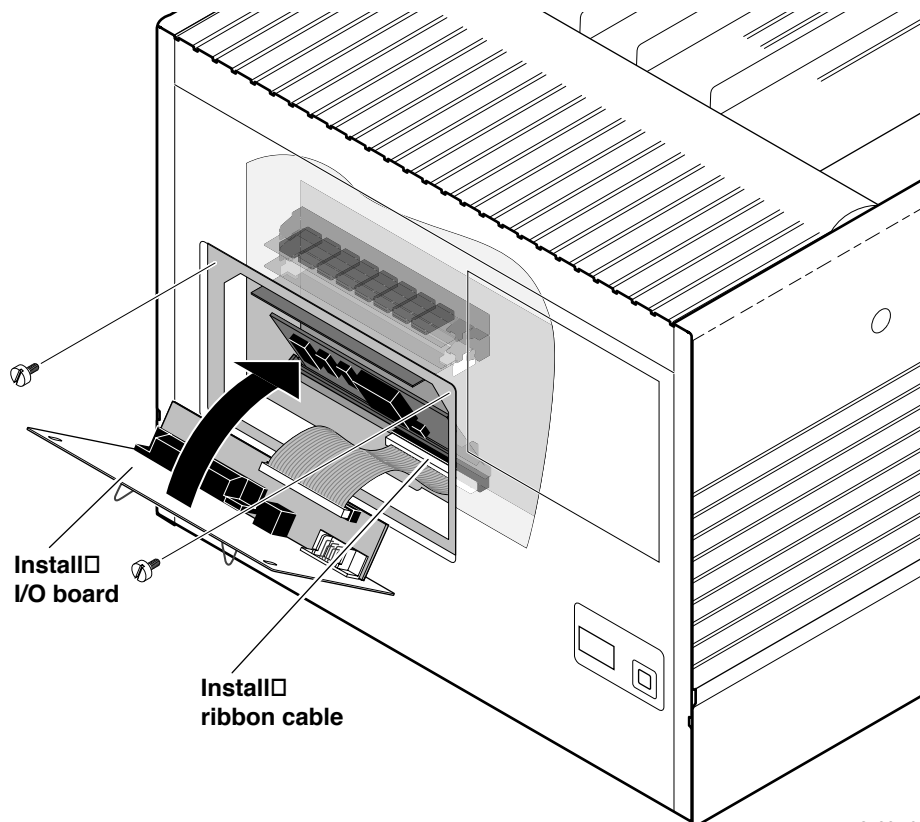

31865-06

5. Reconnect the interface cables. Turn on the printer and examine the startup page it should automatically print out. Refer to the *Phaser 240 Color Printer User Manual* for details on connecting interface cables and making prints.

## Return the old boards to Tektronix

1. Repack the old image processor and engine board (new or old) in the anti-static bags. Put the anti-static bags inside the shipping box.
2. In the U.S.A.:
  - a. Write the printer's original serial number on the shipping return label. attach the shipping label to the box, covering the original shipping label.
  - b. Securely tape the box closed and mail it to the pre-addresses location. Postage is prepaid.

Outside the U.S.A.:

- a. Affix the special international shipping return label, included with this upgrade kit, to conceal the original U.S. shipping label.
- b. Write the printer's serial number on the shipping return label.
- c. Tape the box closed and ship the box to Tektronix, using you respective country's shipping method.